

Synthesis, photochromic and chiroptical properties of photoswitchable glycomacrocycles

Jinbiao Jiao,¹ Stéphane Maisonneuve,¹ Yuna Kim,² Juan Xie¹

1. PPSM, ENS Paris-Saclay, CNRS, Université Paris-Saclay, 4 Avenue des Sciences, 91190 Gif-sur-Yvette, France

2. Research Institute for Electronic Science, Hokkaido University, 04-108, Sousei building, Hokkaido, 001-0020, Japan

e-mail: jiao.jinbiao@ens-paris-saclay.fr

Photochromic molecules not only reversibly photomodulate various properties of molecules, but also show more and more increasing interest in remote-controlling chemical reactivity and catalytic activities.¹ Photoswitchable glycoconjugates have also been developed for light-controlled various applications in biology and material sciences.² As a continuing interest in the development of glycomacrocycles,³ we are developing a new intramolecular glycosylation method to access to photoswitchable glycomacrocycles. The principle is to use a photochromic molecule for template together, through cleavable functions, glycosyl donor and acceptor via non-reacting centers (Scheme 1). It is to be noticed that the carbohydrate anomeric configuration has an important influence on the properties and biological functions of carbohydrates, so stereoselective glycosylation is very important for the glycoscience. We will report the results by using azobenene as photochromic template to realize the intramolecular glycosylation. The photoswitching properties as well as the chiroptical properties of azobenzene-based glycomacrocycles will also be presented.

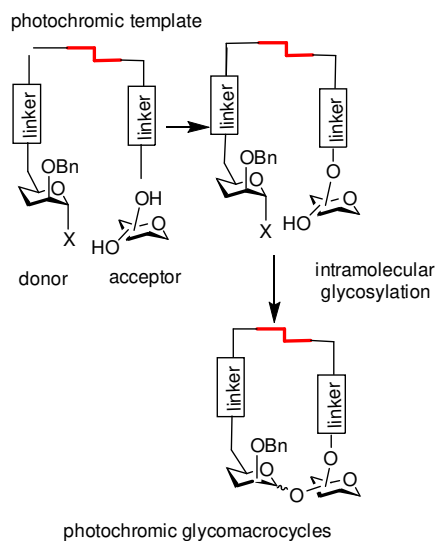

Scheme 1: Glycosylation with photochromic template

References:

1. (a) Brieke, C., Rohrbach, F., Gottschalk, A., Mayer, G., Heckel, *Angew. Chem. Int. Ed.* **2012**, *51*, 8446; (b) Lerch, M. M., Hansen, M. J., van Dam, G. M., Szymański, W., Feringa, B. L. *Angew. Chem. Int. Ed.* **2016**, *55*, 10978; (c) Yu, Z., Hecht, S. *Chem. Commun.* **2016**, *52*, 6639; (d) R. Dorel, B. L. Feringa, *Chem. Commun.* **2019**, *55*, 6477-6486.
2. (a) Hu, Y., Tabor, R. F., Wilkinson, B. L. *Org. Biomol. Chem.* **2015**, *13*, 2216; (b) Weber, T., Chandrasekaran, V., Stamer, I., Thygesen, M. B., Terfort, A., Lindhorst, T. K. *Angew. Chem. Int. Ed.* **2014**, *53*, 14583; (c) Ogawa, Y., Yoshiyama, C., Kitaoka, T. *Langmuir* **2012**, *28*, 4404.
3. (a) Xie, J., Bogliotti, N. *Chem. Rev.* **2014**, *114*, 7678 ; (b) Lin, C., Maisonneuve, S., Métivier, R., Xie, J. *Chem. Eur. J.* **2017**, *23*, 14996; (c) Lin, C., Maisonneuve, S., Theulier, C., Xie, J. *Eur. J. Org. Chem.* **2019**, 1770.